

NO	DESCRIPTION	MATERIAL	Q'TY	FINISH	REMARK
1	BODY 1	BRASS	1	NICKEL	B-FME0322-N
2	INSULATION	DELRIN	1	DELRIN	I-0066D
3	PIN	BRASS	1	GOLD	P-FME0604-G
4	BODY 2	BRASS	1	NICKEL	B-UHF0221-N
5	INSULATION	DELRIN	1	DELRIN	I-0039D
6	BODY 3	BRASS	1	NICKEL	B-UHF0866-N
7	WASHER	PH.BRONZE	1	NICKEL	W-0029-N

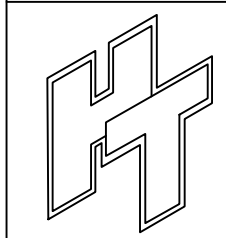
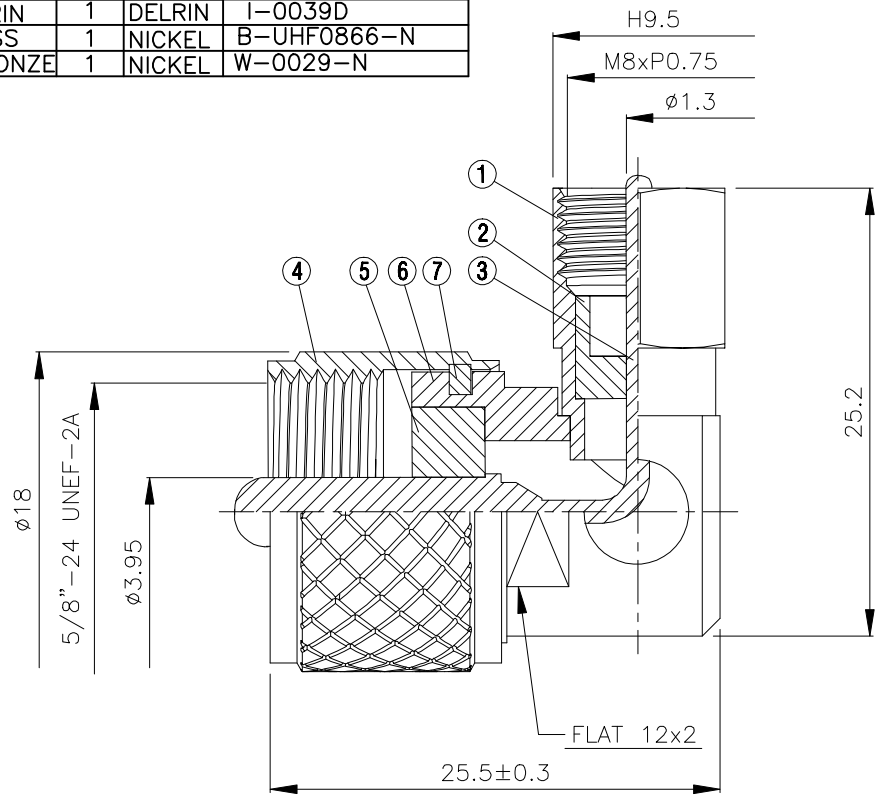
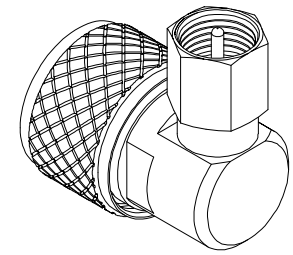

HUS-TSAN GROUP CO., LTD.
P.O.BOX 40-76.TAINAN.TAWAN,R.O.C.
TITLE FME MALE ANGLE - UHF MALE ADAPTOR
PART NO. FME-45-DGN
DRAWING NO. FME 45 DGN

DRAWN	MARY	DATE	94.02.17
CHECKED	蘇姿潔	DATE	
Q.A.	馮健華	DATE	
APPROVAL	徐煥霖	DATE	
REVISION		DATE	

DIMENSIONS ARE IN MILLIMETERS			
UNLESS OTHERWISE SPECIFIED TOLERANCE			
0.5-5=±0.2	120-315=±1		
5-30=±0.4	315-1000=±1.6		
30-120±0.6	1000-2000=±2.4		
SCALE	4:1	SIZE	A

REVISION	
DESCRIPTION	ENGINEER